

FX SERIES PRO



			FX-6 PRO	FX-25 PRO	FX-35 PRO	FX-45 PRO	FX-55 PRO	FX-65 PRO	FX-75 PRO	FX-95 PRO	FX-110 PRO	FX-130 PRO	FX-170 PRO
(1)	Excavatorclass	T.	0.5 - 1.2	1.0 - 2.4	2.0 - 3.8	2.6 - 4.5	3.6 - 6.5	5 - 8.5	6.5 - 10	9 - 15	12 - 18	14 - 21	16 - 24
	Weight	Kg.	60	122	195	260	345	470	570	840	930	1190	1420
	Long stroke	BPM	800 - 1200	550 - 1000	600 - 1500	550 - 1300	380 - 1100	400 - 800	350 - 700	350 - 600	350 - 550	350 - 550	320 - 500
	Short stroke	BPM	-	-	-	-	-	600 - 1100	490 - 1000	600 - 900	600 - 900	400 - 700	400 - 650
	Workingpressure	Bar	60 - 130	90 - 120	90 - 120	110 - 165	120 - 165	140 - 170	140 - 170	140 - 180	140 - 180	160 - 190	160 - 190
	Oilflow	L/min.	18 - 25	15 - 35	23 - 70	35 - 70	40 - 110	45 - 100	50 - 110	75 - 120	80 - 140	100 - 150	100 - 155
	Chisel diameter	mm.	40	45	57	70	75	80	90	95	105	115	125
	Impact energy (Theor.)	J	216	336	448	710	1320	1700	2137	2880	3666	4146	4712

			FX-190 PRO	FX-210 PRO	FX-260 PRO	FX-320 PRO	FX-380 PRO	FX-460 PRO	FX-520 PRO	FX-680 PRO	FX-740 PRO	FX-820 PRO	FX-1200 PRO
(1)	Excavatorclass	T.	18 - 26	20 - 28	24 - 32	25 - 36	30 - 42	34 - 50	42 - 60	47 - 78	60 - 90	65 - 100	88 - 150
	Weight	Kg.	1560	1820	2050	2380	2800	3200	3800	4600	5800	7100	10400
	Long stroke	BPM	320 - 480	340 - 450	270 - 400	250 - 380	230 - 400	230 - 345	230 - 330	270 - 380	280 - 355	280 - 350	250 - 320
	Short stroke	BPM	400 - 600	420 - 550	330 - 500	300 - 450	270 - 470	270 - 410	270 - 550	380 - 530	380 - 485	320 - 520	290 - 380
	Workingpressure	Bar	160 - 190	160 - 190	160 - 190	160 - 190	160 - 190	160 - 190	160 - 190	160 - 190	160 - 190	160 - 190	160 - 190
	Oilflow	L/min.	120 - 170	120 - 190	150 - 210	180 - 240	200 - 260	220 - 280	240 - 320	260 - 360	310 - 390	360 - 450	450 - 530
	Chisel diameter	mm.	135	135	145	150	155	165	175	180	200	205	240
	Impact energy (Theor.)	J	5383	6418	7980	9600	9880	12336	14739	14400	16698	19543	25175

(1) Recommended excavator / attachment combination

Soundproofed

Vibration Damper

Bigger Nitrogen chamber

Frequency valve

Bigger control valve

Auto Lube

Accumulator

Heavy Duty Housing

Retainer pin

Piston

Chisel

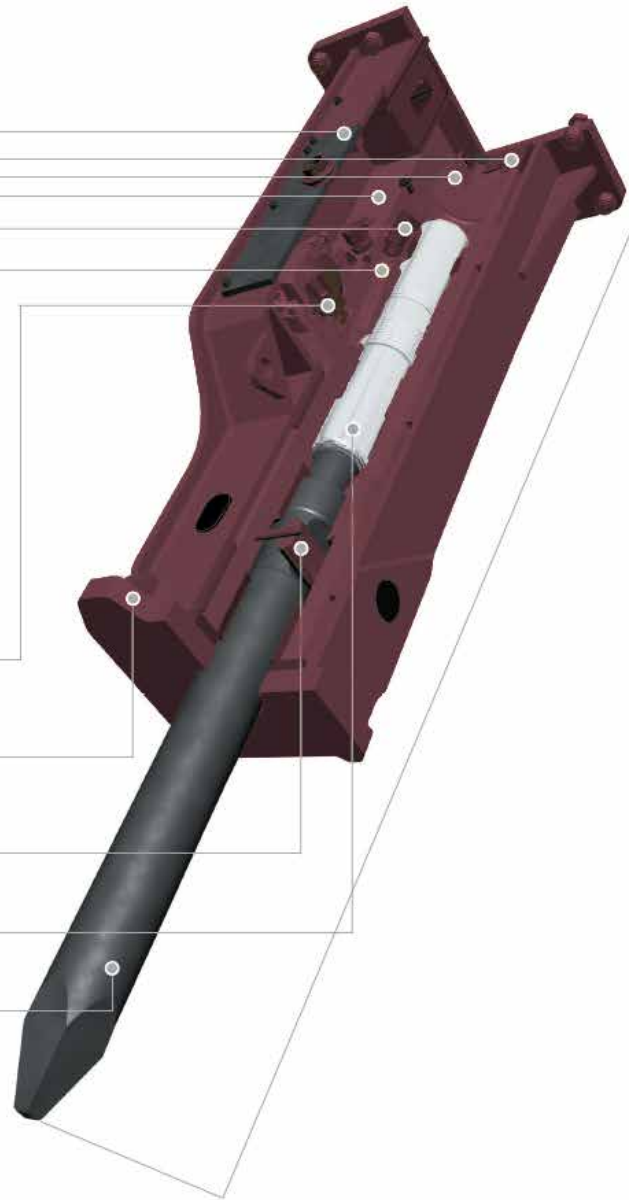

Hydraram FX-Series Pro

- AutoLubrication
- AutoStop
- DustControl
- PowerSelect
- VibrosilencedPro
- EnergyRecovery